

## Leveling Feet

Steel

### SPECIFICATION

#### Types (Base plate)

- Type **A0**: Without rubber pad
- Type **B0**: Without rubber pad, with 2 mounting holes
- Type **A1**: With rubber pad, clipped on, black
- Type **A3**: With rubber pad, vulcanized, black

#### Version (Screw)

- Version **S**: Without nut, external hex at the bottom
- Version **SK**: With nut, external hex at the bottom
- Version **U**: Without nut, hex socket at the top and wrench flat at the bottom
- Version **UK**: With nut, hex socket at the top and wrench flat at the bottom
- Version **X**: External hex with internal thread

Base plate

Steel, zinc plated, blue passivated

Threaded stem

Steel, zinc plated, blue passivated

Hex nut ISO 4032

Steel, zinc plated, blue passivated

Rubber pad

Clipped on

Black, TPE (Santoprene®)

≈ 80 Shore A

Rubber pad

Vulcanized

Black, NBR (Perbunan®)

70 ± 5 Shore A

### INFORMATION

Leveling feet GN 40 can be used in a host of combinations of base plates and adjustable spindle versions.

The base plate with the rubber pad protects sensitive surfaces and reduces lateral slippage. The type B0 can also be fastened to the mounting surface through two holes.

The leveling feet are supplied fully assembled and are not removable.

### TECHNICAL INFORMATION

- Plastic Characteristics (see page A2)



### LOAD RATING OF LEVELING FEET

The static load bearing capacity given in the table rests on a test series in which the load has been applied perpendicular to the base plate (without rubber underlay). For the values given in the table, the strain relief may result in minor deformations of the base plate.

Bending and buckling stress which often occurs in practice results in a lower load bearing capacity of the adjustment spindle and may have to be taken into account.

Also, the spindle strength is assumed to be  $\geq 500 \text{ N/mm}^2$ .

The details given on strength are nonbinding guide values without any liability. In general, they do not constitute a warranty of quality.

The user must determine from case to case if a product is suitable for the intended purpose or use. Environmental factors may influence the stated values.

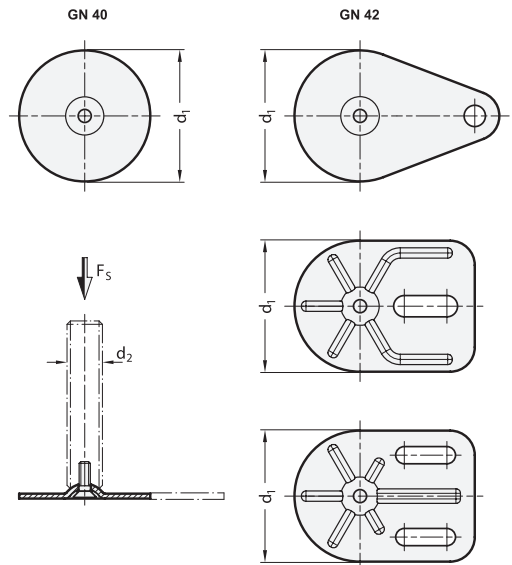

Versions of threaded stem		
<p><b>S / SK:</b> External hex at the bottom at <math>d_2</math> M 8, M 10, M 12</p>	<p><b>U / UK:</b> Hex socket at the top and wrench flat at the bottom at <math>d_2</math> M 16, M 20, M 24</p>	<p><b>X:</b> External hex with internal thread at <math>d_2</math> M 8, M 10, M 12, M 16, M 20</p>

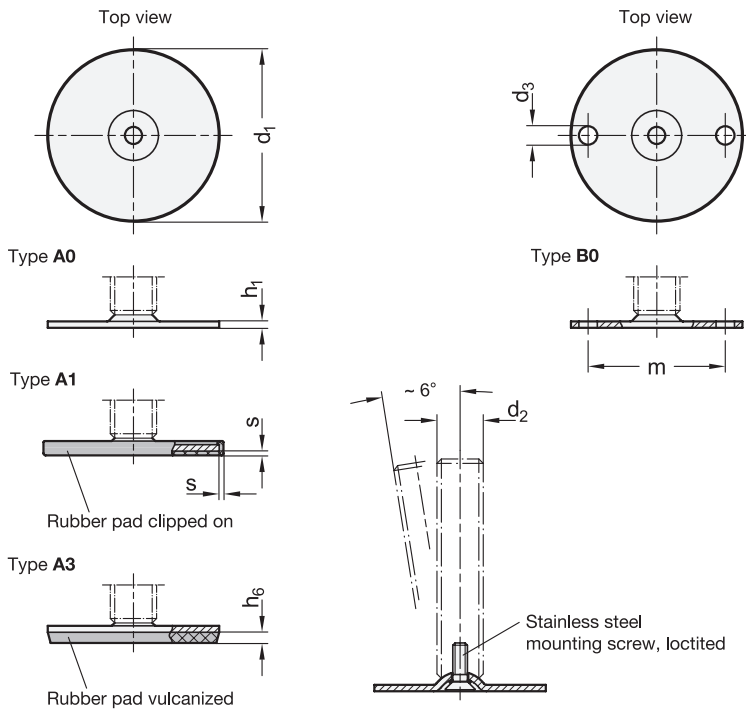

Versions of threaded stem

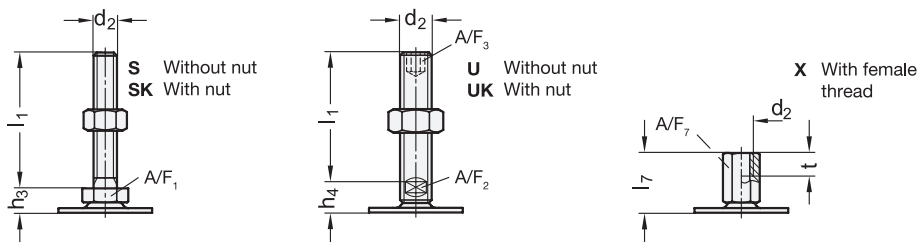

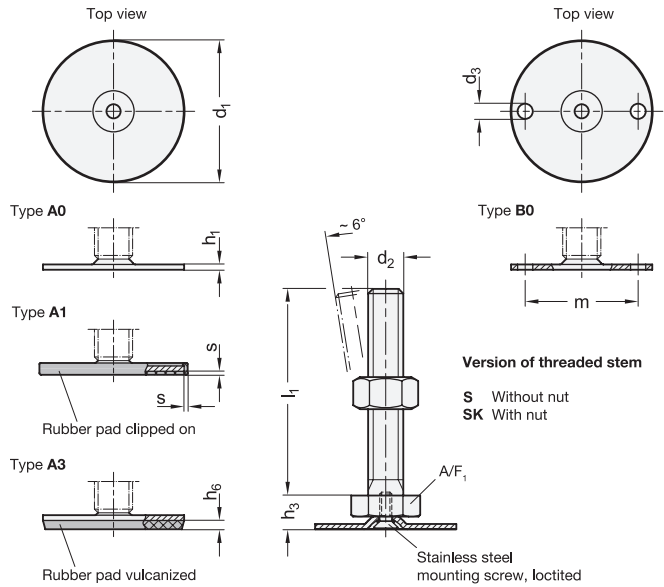

\* Complete with version of the Leveling feet  
(External hex at the bottom)

**S** without nut  
**SK** with nut

### GN 40-S/SK

Description	d1	d2	l1	d3	h1	h6	m	s	h3	A/F 1	Static Load Fs in kN	⚖️
GN 40-40-M8-40-A0-*	40	M 8	40	-	2	-	30	-	11	17	7	47
GN 40-40-M8-40-B0-*	40	M 8	40	5.4	2	-	30	-	11	17	7	43
GN 40-40-M8-40-A1-*	40	M 8	40	-	2	-	30	1.5	11	17	7	50
GN 40-40-M8-40-A3-*	40	M 8	40	-	2	3.5	30	-	11	17	7	45
GN 40-40-M8-50-A0-*	40	M 8	50	-	2	-	30	-	11	17	7	51
GN 40-40-M8-50-B0-*	40	M 8	50	5.4	2	-	30	-	11	17	7	43
GN 40-40-M8-50-A1-*	40	M 8	50	-	2	-	30	1.5	11	17	7	53
GN 40-40-M8-50-A3-*	40	M 8	50	-	2	3.5	30	-	11	17	7	40
GN 40-40-M8-63-A0-*	40	M 8	63	-	2	-	30	-	11	17	7	55
GN 40-40-M8-63-B0-*	40	M 8	63	5.4	2	-	30	-	11	17	7	47
GN 40-40-M8-63-A1-*	40	M 8	63	-	2	-	30	1.5	11	17	7	57
GN 40-40-M8-63-A3-*	40	M 8	63	-	2	3.5	30	-	11	17	7	52
GN 40-40-M10-50-A0-*	40	M 10	50	-	2	-	30	-	11	17	7	55
GN 40-40-M10-50-B0-*	40	M 10	50	5.4	2	-	30	-	11	17	7	73
GN 40-40-M10-50-A1-*	40	M 10	50	-	2	-	30	1.5	11	17	7	58
GN 40-40-M10-50-A3-*	40	M 10	50	-	2	3.5	30	-	11	17	7	60
GN 40-40-M10-60-A0-*	40	M 10	60	-	2	-	30	-	11	17	7	60
GN 40-40-M10-60-B0-*	40	M 10	60	5.4	2	-	30	-	11	17	7	77
GN 40-40-M10-60-A1-*	40	M 10	60	-	2	-	30	1.5	11	17	7	60
GN 40-40-M10-60-A3-*	40	M 10	60	-	2	3.5	30	-	11	17	7	83
GN 40-40-M10-80-A0-*	40	M 10	80	-	2	-	30	-	11	17	7	100
GN 40-40-M10-80-B0-*	40	M 10	80	5.4	2	-	30	-	11	17	7	87
GN 40-40-M10-80-A1-*	40	M 10	80	-	2	-	30	1.5	11	17	7	82
GN 40-40-M10-80-A3-*	40	M 10	80	-	2	3.5	30	-	11	17	7	70
GN 40-40-M10-100-A0-*	40	M 10	100	-	2	-	30	-	11	17	7	85
GN 40-40-M10-100-B0-*	40	M 10	100	5.4	2	-	30	-	11	17	7	80
GN 40-40-M10-100-A1-*	40	M 10	100	-	2	-	30	1.5	11	17	7	83
GN 40-40-M10-100-A3-*	40	M 10	100	-	2	3.5	30	-	11	17	7	100
GN 40-40-M12-60-A0-*	40	M 12	60	-	2	-	30	-	11	17	7	90
GN 40-40-M12-60-B0-*	40	M 12	60	5.4	2	-	30	-	11	17	7	90
GN 40-40-M12-60-A1-*	40	M 12	60	-	2	-	30	1.5	11	17	7	70
GN 40-40-M12-60-A3-*	40	M 12	60	-	2	3.5	30	-	11	17	7	77
GN 40-40-M12-80-A0-*	40	M 12	80	-	2	-	30	-	11	17	7	102
GN 40-40-M12-80-B0-*	40	M 12	80	5.4	2	-	30	-	11	17	7	105
GN 40-40-M12-80-A1-*	40	M 12	80	-	2	-	30	1.5	11	17	7	80
GN 40-40-M12-80-A3-*	40	M 12	80	-	2	3.5	30	-	11	17	7	110
GN 40-40-M12-100-A0-*	40	M 12	100	-	2	-	30	-	11	17	7	118
GN 40-40-M12-100-B0-*	40	M 12	100	5.4	2	-	30	-	11	17	7	119
GN 40-40-M12-100-A1-*	40	M 12	100	-	2	-	30	1.5	11	17	7	120
GN 40-40-M12-100-A3-*	40	M 12	100	-	2	3.5	30	-	11	17	7	124
GN 40-40-M12-125-A0-*	40	M 12	125	-	2	-	30	-	11	17	7	120
GN 40-40-M12-125-B0-*	40	M 12	125	5.4	2	-	30	-	11	17	7	135
GN 40-40-M12-125-A1-*	40	M 12	125	-	2	-	30	1.5	11	17	7	140
GN 40-40-M12-125-A3-*	40	M 12	125	-	2	3.5	30	-	11	17	7	146

Weight Version S

\* Complete with version of the Leveling feet  
(External hex at the bottom)

**S** without nut      **SK** with nut

**GN 40-S/SK**

Description	d1	d2	l1	d3	h1	h6	m	s	h3	A/F 1	Static Load Fs in kN	⚖️
GN 40-50-M8-40-A0-*	50	M 8	40	-	2.5	-	38	-	11	17	8	66
GN 40-50-M8-40-B0-*	50	M 8	40	5.4	2.5	-	38	-	11	17	8	58
GN 40-50-M8-40-A1-*	50	M 8	40	-	2.5	-	38	2	11	17	8	71
GN 40-50-M8-40-A3-*	50	M 8	40	-	2.5	4	38	-	11	17	8	69
GN 40-50-M8-50-A0-*	50	M 8	50	-	2.5	-	38	-	11	17	8	69
GN 40-50-M8-50-B0-*	50	M 8	50	6.6	2.5	-	38	-	11	17	8	61
GN 40-50-M8-50-A1-*	50	M 8	50	-	2.5	-	38	2	11	17	8	72
GN 40-50-M8-50-A3-*	50	M 8	50	-	2.5	4	38	-	11	17	8	69
GN 40-50-M8-63-A0-*	50	M 8	63	-	2.5	-	38	-	11	17	8	72
GN 40-50-M8-63-B0-*	50	M 8	63	6.6	2.5	-	38	-	11	17	8	65
GN 40-50-M8-63-A1-*	50	M 8	63	-	2.5	-	38	2	11	17	8	79
GN 40-50-M8-63-A3-*	50	M 8	63	-	2.5	4	38	-	11	17	8	73
GN 40-50-M10-50-A0-*	50	M 10	50	-	2.5	-	38	-	11	17	8	82
GN 40-50-M10-50-B0-*	50	M 10	50	6.6	2.5	-	38	-	11	17	8	91
GN 40-50-M10-50-A1-*	50	M 10	50	-	2.5	-	38	2	11	17	8	89
GN 40-50-M10-50-A3-*	50	M 10	50	-	2.5	4	38	-	11	17	8	87
GN 40-50-M10-60-A0-*	50	M 10	60	-	2.5	-	38	-	11	17	8	80
GN 40-50-M10-60-B0-*	50	M 10	60	6.6	2.5	-	38	-	11	17	8	95
GN 40-50-M10-60-A1-*	50	M 10	60	-	2.5	-	38	2	11	17	8	80
GN 40-50-M10-60-A3-*	50	M 10	60	-	2.5	4	38	-	11	17	8	104
GN 40-50-M10-80-A0-*	50	M 10	80	-	2.5	-	38	-	11	17	8	98
GN 40-50-M10-80-B0-*	50	M 10	80	6.6	2.5	-	38	-	11	17	8	80
GN 40-50-M10-80-A1-*	50	M 10	80	-	2.5	-	38	2	11	17	8	103
GN 40-50-M10-80-A3-*	50	M 10	80	-	2.5	4	38	-	11	17	8	100
GN 40-50-M10-100-A0-*	50	M 10	100	-	2.5	-	38	-	11	17	8	108
GN 40-50-M10-100-B0-*	50	M 10	100	6.6	2.5	-	38	-	11	17	8	115
GN 40-50-M10-100-A1-*	50	M 10	100	-	2.5	-	38	2	11	17	8	100
GN 40-50-M10-100-A3-*	50	M 10	100	-	2.5	4	38	-	11	17	8	100
GN 40-50-M12-60-A0-*	50	M 12	60	-	2.5	-	38	-	11	17	8	106
GN 40-50-M12-60-B0-*	50	M 12	60	6.6	2.5	-	38	-	11	17	8	108
GN 40-50-M12-60-A1-*	50	M 12	60	-	2.5	-	38	2	11	17	8	90
GN 40-50-M12-60-A3-*	50	M 12	60	-	2.5	4	38	-	11	17	8	220
GN 40-50-M12-80-A0-*	50	M 12	80	-	2.5	-	38	-	11	17	8	119
GN 40-50-M12-80-B0-*	50	M 12	80	6.6	2.5	-	38	-	11	17	8	123
GN 40-50-M12-80-A1-*	50	M 12	80	-	2.5	-	38	2	11	17	8	120
GN 40-50-M12-80-A3-*	50	M 12	80	-	2.5	4	38	-	11	17	8	131
GN 40-50-M12-100-A0-*	50	M 12	100	-	2.5	-	38	-	11	17	8	137
GN 40-50-M12-100-B0-*	50	M 12	100	6.6	2.5	-	38	-	11	17	8	137
GN 40-50-M12-100-A1-*	50	M 12	100	-	2.5	-	38	2	11	17	8	130
GN 40-50-M12-100-A3-*	50	M 12	100	-	2.5	4	38	-	11	17	8	145
GN 40-50-M12-125-A0-*	50	M 12	125	-	2.5	-	38	-	11	17	8	140
GN 40-50-M12-125-B0-*	50	M 12	125	6.6	2.5	-	38	-	11	17	8	140
GN 40-50-M12-125-A1-*	50	M 12	125	-	2.5	-	38	2	11	17	8	140
GN 40-50-M12-125-A3-*	50	M 12	125	-	2.5	4	38	-	11	17	8	110
GN 40-60-M8-40-A0-*	60	M 8	40	-	2.5	-	48	-	11	17	8	84
GN 40-60-M8-40-B0-*	60	M 8	40	6.6	2.5	-	48	-	11	17	8	75
GN 40-60-M8-40-A1-*	60	M 8	40	-	2.5	-	48	2	11	17	8	91
GN 40-60-M8-40-A3-*	60	M 8	40	-	2.5	4.5	48	-	11	17	8	89
GN 40-60-M8-50-A0-*	60	M 8	50	-	2.5	-	48	-	11	17	8	863
GN 40-60-M8-50-B0-*	60	M 8	50	6.6	2.5	-	48	-	11	17	8	78
GN 40-60-M8-50-A1-*	60	M 8	50	-	2.5	-	48	2	11	17	8	95
GN 40-60-M8-50-A3-*	60	M 8	50	-	2.5	4.5	48	-	11	17	8	92
GN 40-60-M8-63-A0-*	60	M 8	63	-	2.5	-	48	-	11	17	8	80
GN 40-60-M8-63-B0-*	60	M 8	63	6.6	2.5	-	48	-	11	17	8	82
GN 40-60-M8-63-A1-*	60	M 8	63	-	2.5	-	48	2	11	17	8	95
GN 40-60-M8-63-A3-*	60	M 8	63	-	2.5	4.5	48	-	11	17	8	100

Weight Version S



Leveling elements 11



Leveling elements 11

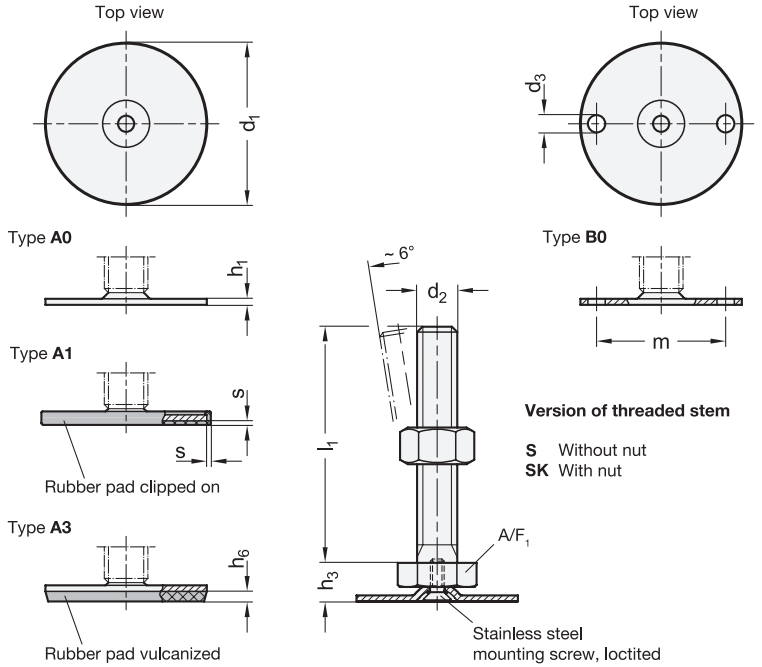

\* Complete with version of the Leveling feet (External hex at the bottom)

**S** without nut  
**SK** with nut

**GN 40-S/SK**

Description	d1	d2	l1	d3	h1	h6	m	s	h3	A/F1	Static Load Fs in kN	⚖️
GN 40-60-M10-50-A0-*	60	M10	50	-	2.5	-	48	-	11	17	10	100
GN 40-60-M10-50-B0-*	60	M10	50	6.6	2.5	-	48	-	11	17	10	107
GN 40-60-M10-50-A1-*	60	M10	50	-	2.5	-	48	2	11	17	10	107
GN 40-60-M10-50-A3-*	60	M10	50	-	2.5	4.5	48	-	11	17	10	110
GN 40-60-M10-60-A0-*	60	M10	60	-	2.5	-	48	-	11	17	10	104
GN 40-60-M10-60-B0-*	60	M10	60	6.6	2.5	-	48	-	11	17	10	112
GN 40-60-M10-60-A1-*	60	M10	60	-	2.5	-	48	2	11	17	10	100
GN 40-60-M10-60-A3-*	60	M10	60	-	2.5	4.5	48	-	11	17	10	127
GN 40-60-M10-80-A0-*	60	M10	80	-	2.5	-	48	-	11	17	10	114
GN 40-60-M10-80-B0-*	60	M10	80	6.6	2.5	-	48	-	11	17	10	121
GN 40-60-M10-80-A1-*	60	M10	80	-	2.5	-	48	2	11	17	10	120
GN 40-60-M10-80-A3-*	60	M10	80	-	2.5	4.5	48	-	11	17	10	136
GN 40-60-M10-100-A0-*	60	M10	100	-	2.5	-	48	-	11	17	10	125
GN 40-60-M10-100-B0-*	60	M10	100	6.6	2.5	-	48	-	11	17	10	131
GN 40-60-M10-100-A1-*	60	M10	100	-	2.5	-	48	2	11	17	10	120
GN 40-60-M10-100-A3-*	60	M10	100	-	2.5	4.5	48	-	11	17	10	146
GN 40-60-M12-60-A0-*	60	M12	60	-	2.5	-	48	-	11	17	10	121
GN 40-60-M12-60-B0-*	60	M12	60	6.6	2.5	-	48	-	11	17	10	124
GN 40-60-M12-60-A1-*	60	M12	60	-	2.5	-	48	2	11	17	10	120
GN 40-60-M12-60-A3-*	60	M12	60	-	2.5	4.5	48	-	11	17	10	139
GN 40-60-M12-80-A0-*	60	M12	80	-	2.5	-	48	-	11	17	10	136
GN 40-60-M12-80-B0-*	60	M12	80	6.6	2.5	-	48	-	11	17	10	139
GN 40-60-M12-80-A1-*	60	M12	80	-	2.5	-	48	2	11	17	10	140
GN 40-60-M12-80-A3-*	60	M12	80	-	2.5	4.5	48	-	11	17	10	138
GN 40-60-M12-100-A0-*	60	M12	100	-	2.5	-	48	-	11	17	10	151
GN 40-60-M12-100-B0-*	60	M12	100	6.6	2.5	-	48	-	11	17	10	153
GN 40-60-M12-100-A1-*	60	M12	100	-	2.5	-	48	2	11	17	10	140
GN 40-60-M12-100-A3-*	60	M12	100	-	2.5	4.5	48	-	11	17	10	168
GN 40-60-M12-125-A0-*	60	M12	125	-	2.5	-	48	-	11	17	10	167
GN 40-60-M12-125-B0-*	60	M12	125	6.6	2.5	-	48	-	11	17	10	175
GN 40-60-M12-125-A1-*	60	M12	125	-	2.5	-	48	2	11	17	10	180
GN 40-60-M12-125-A3-*	60	M12	125	-	2.5	4.5	48	-	11	17	10	171

Weight Version S



Leveling elements 11

\* Complete with version of the Leveling feet  
(External hex at the bottom)

**S** without nut      **SK** with nut

### GN 40-S/SK

Description	d1	d2	l1	d3	h1	h6	m	s	h3	A/F 1	Static Load Fs in kN	⚖️
GN 40-80-M8-40-A0-*	80	M 8	40	-	3	-	64	-	12	17	8	170
GN 40-80-M8-40-B0-*	80	M 8	40	6.6	3	-	64	-	12	17	8	135
GN 40-80-M8-40-A1-*	80	M 8	40	-	3	-	64	2	12	17	8	160
GN 40-80-M8-40-A3-*	80	M 8	40	-	3	5	64	-	12	17	8	166
GN 40-80-M8-50-A0-*	80	M 8	50	-	3	-	64	-	12	17	8	125
GN 40-80-M8-50-B0-*	80	M 8	50	8.6	3	-	64	-	12	17	8	138
GN 40-80-M8-50-A1-*	80	M 8	50	-	3	-	64	2	12	17	8	160
GN 40-80-M8-50-A3-*	80	M 8	50	-	3	5	64	-	12	17	8	169
GN 40-80-M8-63-A0-*	80	M 8	63	-	3	-	64	-	12	17	8	160
GN 40-80-M8-63-B0-*	80	M 8	63	8.6	3	-	64	-	12	17	8	142
GN 40-80-M8-63-A1-*	80	M 8	63	-	3	-	64	2	12	17	8	160
GN 40-80-M8-63-A3-*	80	M 8	63	-	3	5	64	-	12	17	8	173
GN 40-80-M10-50-A0-*	80	M 10	50	-	3	-	64	-	12	17	10	166
GN 40-80-M10-50-B0-*	80	M 10	50	8.6	3	-	64	-	12	17	10	168
GN 40-80-M10-50-A1-*	80	M 10	50	-	3	-	64	2	12	17	10	170
GN 40-80-M10-50-A3-*	80	M 10	50	-	3	5	64	-	12	17	10	190
GN 40-80-M10-60-A0-*	80	M 10	60	-	3	-	64	-	12	17	10	180
GN 40-80-M10-60-B0-*	80	M 10	60	8.6	3	-	64	-	12	17	10	173
GN 40-80-M10-60-A1-*	80	M 10	60	-	3	-	64	2	12	17	10	180
GN 40-80-M10-60-A3-*	80	M 10	60	-	3	5	64	-	12	17	10	204
GN 40-80-M10-80-A0-*	80	M 10	80	-	3	-	64	-	12	17	10	180
GN 40-80-M10-80-B0-*	80	M 10	80	8.6	3	-	64	-	12	17	10	182
GN 40-80-M10-80-A1-*	80	M 10	80	-	3	-	64	2	12	17	10	200
GN 40-80-M10-80-A3-*	80	M 10	80	-	3	5	64	-	12	17	10	213
GN 40-80-M10-100-A0-*	80	M 10	100	-	3	-	64	-	12	17	10	189
GN 40-80-M10-100-B0-*	80	M 10	100	8.6	3	-	64	-	12	17	10	192
GN 40-80-M10-100-A1-*	80	M 10	100	-	3	-	64	2	12	17	10	200
GN 40-80-M10-100-A3-*	80	M 10	100	-	3	5	64	-	12	17	10	223
GN 40-80-M12-60-A0-*	80	M 12	60	-	3	-	64	-	12	17	12	180
GN 40-80-M12-60-B0-*	80	M 12	60	8.6	3	-	64	-	12	17	12	185
GN 40-80-M12-60-A1-*	80	M 12	60	-	3	-	64	2	12	17	12	205
GN 40-80-M12-60-A3-*	80	M 12	60	-	3	5	64	-	12	17	12	202
GN 40-80-M12-80-A0-*	80	M 12	80	-	3	-	64	-	12	17	12	201
GN 40-80-M12-80-B0-*	80	M 12	80	8.6	3	-	64	-	12	17	12	200
GN 40-80-M12-80-A1-*	80	M 12	80	-	3	-	64	2	12	17	12	200
GN 40-80-M12-80-A3-*	80	M 12	80	-	3	5	64	-	12	17	12	231
GN 40-80-M12-100-A0-*	80	M 12	100	-	3	-	64	-	12	17	12	215
GN 40-80-M12-100-B0-*	80	M 12	100	8.6	3	-	64	-	12	17	12	214
GN 40-80-M12-100-A1-*	80	M 12	100	-	3	-	64	2	12	17	12	230
GN 40-80-M12-100-A3-*	80	M 12	100	-	3	5	64	-	12	17	12	245
GN 40-80-M12-125-A0-*	80	M 12	125	-	3	-	64	-	12	17	12	233
GN 40-80-M12-125-B0-*	80	M 12	125	8.6	3	-	64	-	12	17	12	245
GN 40-80-M12-125-A1-*	80	M 12	125	-	3	-	64	2	12	17	12	235
GN 40-80-M12-125-A3-*	80	M 12	125	-	3	5	64	-	12	17	12	267

Weight Version S

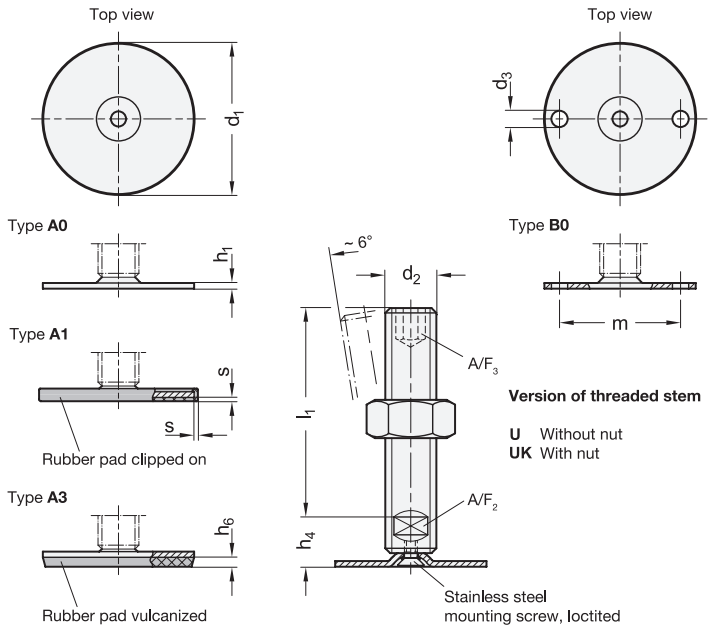

\* Complete with version of the Leveling feet (Hex socket at the top / Wrench at the bottom)

**U** without nut  
**UK** with nut

**GN 40-U/UK**

Description	d1	d2	l1	d3	h1	h6	m	s	h4	A/F 2	A/F 3	Static Load Fs in kN	⚖
GN 40-40-M16-75-A0-*	40	M 16	75	-	2	-	30	-	17	12	8	7	153
GN 40-40-M16-75-A1-*	40	M 16	75	-	2	-	30	1.5	17	12	8	7	120
GN 40-40-M16-75-A3-*	40	M 16	75	-	2	3.5	30	-	17	12	8	7	127
GN 40-40-M16-100-A0-*	40	M 16	100	-	2	-	30	-	17	12	8	7	192
GN 40-40-M16-100-A1-*	40	M 16	100	-	2	-	30	1.5	17	12	8	7	180
GN 40-40-M16-100-A3-*	40	M 16	100	-	2	3.5	30	-	17	12	8	7	159
GN 40-40-M16-125-A0-*	40	M 16	125	-	2	-	30	-	17	12	8	7	215
GN 40-40-M16-125-A1-*	40	M 16	125	-	2	-	30	1.5	17	12	8	7	220
GN 40-40-M16-125-A3-*	40	M 16	125	-	2	3.5	30	-	17	12	8	7	191
GN 40-40-M16-150-A0-*	40	M 16	150	-	2	-	30	-	17	12	8	7	220
GN 40-40-M16-150-A1-*	40	M 16	150	-	2	-	30	1.5	17	12	8	7	254
GN 40-40-M16-150-A3-*	40	M 16	150	-	2	3.5	30	-	17	12	8	7	223
GN 40-40-M16-200-A0-*	40	M 16	200	-	2	-	30	-	17	12	8	7	320
GN 40-40-M16-200-A1-*	40	M 16	200	-	2	-	30	1.5	17	12	8	7	300
GN 40-40-M16-200-A3-*	40	M 16	200	-	2	3.5	30	-	17	12	8	7	283
GN 40-40-M16-250-A0-*	40	M 16	250	-	2	-	30	-	17	12	8	7	638
GN 40-40-M16-250-A1-*	40	M 16	250	-	2	-	30	1.5	17	12	8	7	618
GN 40-40-M16-250-A3-*	40	M 16	250	-	2	3.5	30	-	17	12	8	7	601
GN 40-50-M16-75-A0-*	50	M 16	75	-	2.5	-	38	-	17	12	8	8	140
GN 40-50-M16-75-B0-*	50	M 16	75	6.6	2.5	-	38	-	17	12	8	8	140
GN 40-50-M16-75-A1-*	50	M 16	75	-	2.5	-	38	2	17	12	8	8	177
GN 40-50-M16-75-A3-*	50	M 16	75	-	2.5	4	38	-	17	12	8	8	149
GN 40-50-M16-100-A0-*	50	M 16	100	-	2.5	-	38	-	17	12	8	8	205
GN 40-50-M16-100-B0-*	50	M 16	100	6.6	2.5	-	38	-	17	12	8	8	172
GN 40-50-M16-100-A1-*	50	M 16	100	-	2.5	-	38	2	17	12	8	8	213
GN 40-50-M16-100-A3-*	50	M 16	100	-	2.5	4	38	-	17	12	8	8	181
GN 40-50-M16-125-A0-*	50	M 16	125	-	2.5	-	38	-	17	12	8	8	243
GN 40-50-M16-125-B0-*	50	M 16	125	6.6	2.5	-	38	-	17	12	8	8	204
GN 40-50-M16-125-A1-*	50	M 16	125	-	2.5	-	38	2	17	12	8	8	241
GN 40-50-M16-125-A3-*	50	M 16	125	-	2.5	4	38	-	17	12	8	8	200
GN 40-50-M16-150-A0-*	50	M 16	150	-	2.5	-	38	-	17	12	8	8	268
GN 40-50-M16-150-B0-*	50	M 16	150	6.6	2.5	-	38	-	17	12	8	8	236
GN 40-50-M16-150-A1-*	50	M 16	150	-	2.5	-	38	2	17	12	8	8	280
GN 40-50-M16-150-A3-*	50	M 16	150	-	2.5	4	38	-	17	12	8	8	245
GN 40-50-M16-200-A0-*	50	M 16	200	-	2.5	-	38	-	17	12	8	8	331
GN 40-50-M16-200-B0-*	50	M 16	200	6.6	2.5	-	38	-	17	12	8	8	296
GN 40-50-M16-200-A1-*	50	M 16	200	-	2.5	-	38	2	17	12	8	8	340
GN 40-50-M16-200-A3-*	50	M 16	200	-	2.5	4	38	-	17	12	8	8	305

Weight Version U

\* Complete with version of the Leveling feet  
(Hex socket at the top / Wrench at the bottom)

**U** without nut      **UK** with nut

**GN 40-U/UK**

Description	d1	d2	l1	d3	h1	h6	m	s	h4	A/F 2	A/F 3	Static Load Fs in kN	⚖️
GN 40-50-M16-250-A0-*	50	M16	250	-	2.5	-	38	-	17	12	8	8	360
GN 40-50-M16-250-B0-*	50	M16	250	6.6	2.5	-	38	-	17	12	8	8	358
GN 40-50-M16-250-A1-*	50	M16	250	-	2.5	-	38	2	17	12	8	8	366
GN 40-50-M16-250-A3-*	50	M16	250	-	2.5	4	38	-	17	12	8	8	367
GN 40-60-M16-75-A0-*	60	M16	75	-	2.5	-	48	-	17	12	8	10	192
GN 40-60-M16-75-B0-*	60	M16	75	6.6	2.5	-	48	-	17	12	8	10	157
GN 40-60-M16-75-A1-*	60	M16	75	-	2.5	-	48	2	17	12	8	10	200
GN 40-60-M16-75-A3-*	60	M16	75	-	2.5	4.5	48	-	17	12	8	10	172
GN 40-60-M16-100-A0-*	60	M16	100	-	2.5	-	48	-	17	12	8	10	180
GN 40-60-M16-100-B0-*	60	M16	100	6.6	2.5	-	48	-	17	12	8	10	189
GN 40-60-M16-100-A1-*	60	M16	100	-	2.5	-	48	2	17	12	8	10	200
GN 40-60-M16-100-A3-*	60	M16	100	-	2.5	4.5	48	-	17	12	8	10	207
GN 40-60-M16-125-A0-*	60	M16	125	-	2.5	-	48	-	17	12	8	10	259
GN 40-60-M16-125-B0-*	60	M16	125	6.6	2.5	-	48	-	17	12	8	10	221
GN 40-60-M16-125-A1-*	60	M16	125	-	2.5	-	48	2	17	12	8	10	240
GN 40-60-M16-125-A3-*	60	M16	125	-	2.5	4.5	48	-	17	12	8	10	236
GN 40-60-M16-150-A0-*	60	M16	150	-	2.5	-	48	-	17	12	8	10	283
GN 40-60-M16-150-B0-*	60	M16	150	6.6	2.5	-	48	-	17	12	8	10	253
GN 40-60-M16-150-A1-*	60	M16	150	-	2.5	-	48	2	17	12	8	10	300
GN 40-60-M16-150-A3-*	60	M16	150	-	2.5	4.5	48	-	17	12	8	10	268
GN 40-60-M16-200-A0-*	60	M16	200	-	2.5	-	48	-	17	12	8	10	312
GN 40-60-M16-200-B0-*	60	M16	200	6.6	2.5	-	48	-	17	12	8	10	313
GN 40-60-M16-200-A1-*	60	M16	200	-	2.5	-	48	2	17	12	8	10	320
GN 40-60-M16-200-A3-*	60	M16	200	-	2.5	4.5	48	-	17	12	8	10	328
GN 40-60-M16-250-A0-*	60	M16	250	-	2.5	-	48	-	17	12	8	10	666
GN 40-60-M16-250-B0-*	60	M16	250	6.6	2.5	-	48	-	17	12	8	10	631
GN 40-60-M16-250-A1-*	60	M16	250	-	2.5	-	48	2	17	12	8	10	658
GN 40-60-M16-250-A3-*	60	M16	250	-	2.5	4.5	48	-	17	12	8	10	646
GN 40-80-M16-75-A0-*	80	M16	75	-	3	-	64	-	18	12	8	12	220
GN 40-80-M16-75-B0-*	80	M16	75	8.6	3	-	64	-	18	12	8	12	218
GN 40-80-M16-75-A1-*	80	M16	75	-	3	-	64	2	18	12	8	12	220
GN 40-80-M16-75-A3-*	80	M16	75	-	3	5	64	-	18	12	8	12	250
GN 40-80-M16-100-A0-*	80	M16	100	-	3	-	64	-	18	12	8	12	270
GN 40-80-M16-100-B0-*	80	M16	100	8.6	3	-	64	-	18	12	8	12	250
GN 40-80-M16-100-A1-*	80	M16	100	-	3	-	64	2	18	12	8	12	275
GN 40-80-M16-100-A3-*	80	M16	100	-	3	5	64	-	18	12	8	12	282
GN 40-80-M16-125-A0-*	80	M16	125	-	3	-	64	-	18	12	8	12	300
GN 40-80-M16-125-B0-*	80	M16	125	8.6	3	-	64	-	18	12	8	12	282
GN 40-80-M16-125-A1-*	80	M16	125	-	3	-	64	2	18	12	8	12	331
GN 40-80-M16-125-A3-*	80	M16	125	-	3	5	64	-	18	12	8	12	314
GN 40-80-M16-150-A0-*	80	M16	150	-	3	-	64	-	18	12	8	12	320
GN 40-80-M16-150-B0-*	80	M16	150	8.6	3	-	64	-	18	12	8	12	314
GN 40-80-M16-150-A1-*	80	M16	150	-	3	-	64	2	18	12	8	12	380
GN 40-80-M16-150-A3-*	80	M16	150	-	3	5	64	-	18	12	8	12	346
GN 40-80-M16-200-A0-*	80	M16	200	-	3	-	64	-	18	12	8	12	414
GN 40-80-M16-200-B0-*	80	M16	200	8.6	3	-	64	-	18	12	8	12	374
GN 40-80-M16-200-A1-*	80	M16	200	-	3	-	64	2	18	12	8	12	400
GN 40-80-M16-200-A3-*	80	M16	200	-	3	5	64	-	18	12	8	12	406
GN 40-80-M16-250-A0-*	80	M16	250	-	3	-	64	-	18	12	8	12	439
GN 40-80-M16-250-B0-*	80	M16	250	8.6	3	-	64	-	18	12	8	12	436
GN 40-80-M16-250-A1-*	80	M16	250	-	3	-	64	2	18	12	8	12	453
GN 40-80-M16-250-A3-*	80	M16	250	-	3	5	64	-	18	12	8	12	468
GN 40-80-M20-75-A0-*	80	M20	75	-	3	-	64	-	19	15	10	16	347
GN 40-80-M20-75-B0-*	80	M20	75	8.6	3	-	64	-	19	15	10	16	276
GN 40-80-M20-75-A1-*	80	M20	75	-	3	-	64	2	19	15	10	16	360
GN 40-80-M20-75-A3-*	80	M20	75	-	3	5	64	-	19	15	10	16	308

Weight Version U





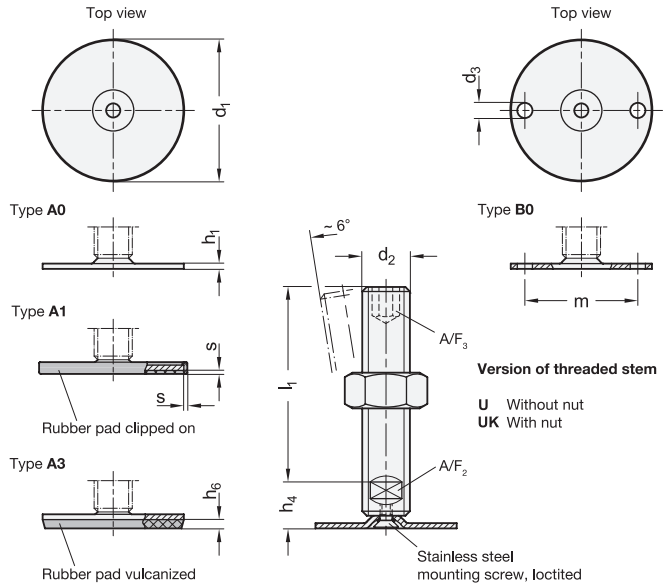

\* Complete with version of the Leveling feet  
(Hex socket at the top / Wrench at the bottom)

**U** without nut  
**UK** with nut

### GN 40-U/UK

Description	d1	d2	l1	d3	h1	h6	m	s	h4	A/F 2	A/F 3	Static Load Fs in kN	⚖
GN 40-80-M20-100-A0-*	80	M 20	100	-	3	-	64	-	19	15	10	16	396
GN 40-80-M20-100-B0-*	80	M 20	100	8.6	3	-	64	-	19	15	10	16	326
GN 40-80-M20-100-A1-*	80	M 20	100	-	3	-	64	2	19	15	10	16	400
GN 40-80-M20-100-A3-*	80	M 20	100	-	3	5	64	-	19	15	10	16	358
GN 40-80-M20-125-A0-*	80	M 20	125	-	3	-	64	-	19	15	10	16	450
GN 40-80-M20-125-B0-*	80	M 20	125	8.6	3	-	64	-	19	15	10	16	376
GN 40-80-M20-125-A1-*	80	M 20	125	-	3	-	64	2	19	15	10	16	459
GN 40-80-M20-125-A3-*	80	M 20	125	-	3	5	64	-	19	15	10	16	408
GN 40-80-M20-150-A0-*	80	M 20	150	-	3	-	64	-	19	15	10	16	494
GN 40-80-M20-150-B0-*	80	M 20	150	8.6	3	-	64	-	19	15	10	16	425
GN 40-80-M20-150-A1-*	80	M 20	150	-	3	-	64	2	19	15	10	16	420
GN 40-80-M20-150-A3-*	80	M 20	150	-	3	5	64	-	19	15	10	16	457
GN 40-80-M20-200-A0-*	80	M 20	200	-	3	-	64	-	19	15	10	16	595
GN 40-80-M20-200-B0-*	80	M 20	200	8.6	3	-	64	-	19	15	10	16	516
GN 40-80-M20-200-A1-*	80	M 20	200	-	3	-	64	2	19	15	10	16	620
GN 40-80-M20-200-A3-*	80	M 20	200	-	3	5	64	-	19	15	10	16	548
GN 40-80-M20-250-A0-*	80	M 20	250	-	3	-	64	-	19	15	10	16	617
GN 40-80-M20-250-B0-*	80	M 20	250	8.6	3	-	64	-	19	15	10	16	611
GN 40-80-M20-250-A1-*	80	M 20	250	-	3	-	64	2	19	15	10	16	631
GN 40-80-M20-250-A3-*	80	M 20	250	-	3	5	64	-	19	15	10	16	643
GN 40-80-M24-100-A0-*	80	M 24	100	-	3	-	64	-	22	19	12	16	542
GN 40-80-M24-100-B0-*	80	M 24	100	8.6	3	-	64	-	22	19	12	16	429
GN 40-80-M24-100-A1-*	80	M 24	100	-	3	-	64	2	22	19	12	16	560
GN 40-80-M24-100-A3-*	80	M 24	100	-	3	5	64	-	22	19	12	16	460
GN 40-80-M24-125-A0-*	80	M 24	125	-	3	-	64	-	22	19	12	16	612
GN 40-80-M24-125-B0-*	80	M 24	125	8.6	3	-	64	-	22	19	12	16	501
GN 40-80-M24-125-A1-*	80	M 24	125	-	3	-	64	2	22	19	12	16	620
GN 40-80-M24-125-A3-*	80	M 24	125	-	3	5	64	-	22	19	12	16	532
GN 40-80-M24-150-A0-*	80	M 24	150	-	3	-	64	-	22	19	12	16	684
GN 40-80-M24-150-B0-*	80	M 24	150	8.6	3	-	64	-	22	19	12	16	573
GN 40-80-M24-150-A1-*	80	M 24	150	-	3	-	64	2	22	19	12	16	650
GN 40-80-M24-150-A3-*	80	M 24	150	-	3	5	64	-	22	19	12	16	604
GN 40-80-M24-200-A0-*	80	M 24	200	-	3	-	64	-	22	19	12	16	820
GN 40-80-M24-200-B0-*	80	M 24	200	8.6	3	-	64	-	22	19	12	16	711
GN 40-80-M24-200-A1-*	80	M 24	200	-	3	-	64	2	22	19	12	16	150
GN 40-80-M24-200-A3-*	80	M 24	200	-	3	5	64	-	22	19	12	16	742
GN 40-80-M24-300-A0-*	80	M 24	300	-	3	-	64	-	22	19	12	16	997
GN 40-80-M24-300-B0-*	80	M 24	300	8.6	3	-	64	-	22	19	12	16	993
GN 40-80-M24-300-A1-*	80	M 24	300	-	3	-	64	2	22	19	12	16	1011
GN 40-80-M24-300-A3-*	80	M 24	300	-	3	5	64	-	22	19	12	16	1024

Weight Version U



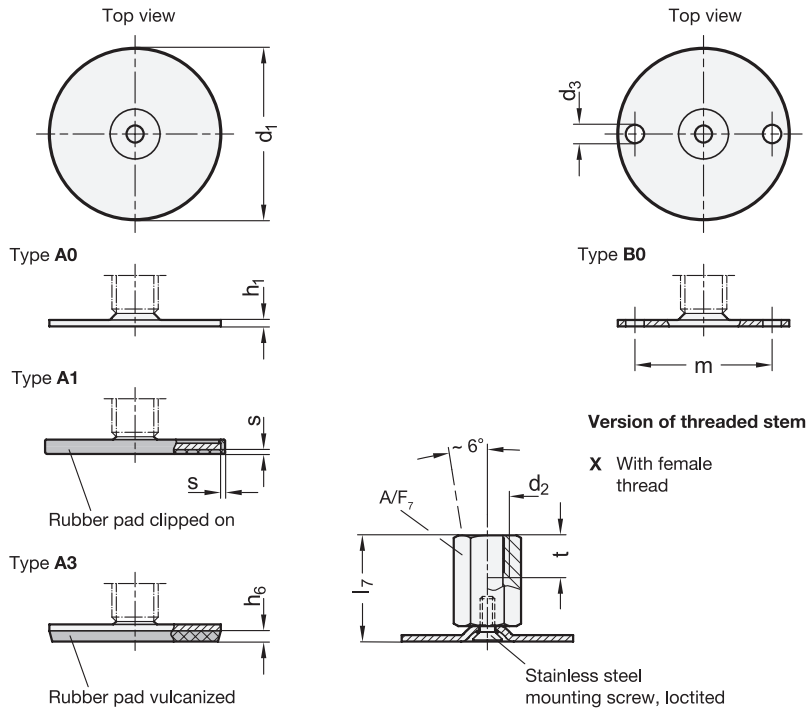

GN 40-X

Description	d1	d2	l7	d3	h1	h6	m	s	A/F 7	t	Static Load Fs in kN	⚖️
GN 40-40-M8-25-A0-X	40	M 8	25	-	2	-	30	-	14	8	7	50
GN 40-40-M8-25-B0-X	40	M 8	25	8.6	2	-	30	-	14	8	7	63
GN 40-40-M8-25-A1-X	40	M 8	25	-	2	-	30	1.5	14	8	7	50
GN 40-40-M8-25-A3-X	40	M 8	25	-	2	3.5	30	-	14	8	7	47
GN 40-40-M10-28-A0-X	40	M 10	28	-	2	-	30	-	14	10	7	40
GN 40-40-M10-28-B0-X	40	M 10	28	5.4	2	-	30	-	14	10	7	61
GN 40-40-M10-28-A1-X	40	M 10	28	-	2	-	30	1.5	14	10	7	45
GN 40-40-M10-28-A3-X	40	M 10	28	-	2	3.5	30	-	14	10	7	66
GN 40-40-M12-31-A0-X	40	M 12	31	-	2	-	30	-	17	12	7	68
GN 40-40-M12-31-B0-X	40	M 12	31	5.4	2	-	30	-	17	12	7	77
GN 40-40-M12-31-A1-X	40	M 12	31	-	2	-	30	1.5	17	12	7	80
GN 40-40-M12-31-A3-X	40	M 12	31	-	2	3.5	30	-	17	12	7	82
GN 40-40-M16-37-A0-X	40	M 16	37	-	2	-	30	-	22	16	7	91
GN 40-40-M16-37-A1-X	40	M 16	37	5.4	2	-	30	1.5	22	16	7	91
GN 40-40-M16-37-A3-X	40	M 16	37	-	2	3.5	30	-	22	16	7	98
GN 40-50-M8-25-A0-X	50	M 8	25	-	2.5	-	38	-	14	8	8	91
GN 40-50-M8-25-B0-X	50	M 8	25	-	2.5	-	38	-	14	8	8	81
GN 40-50-M8-25-A1-X	50	M 8	25	-	2.5	-	38	2	14	8	8	91
GN 40-50-M8-25-A3-X	50	M 8	25	-	2.5	4	38	-	14	8	8	89
GN 40-50-M10-28-A0-X	50	M 10	28	-	2.5	-	38	-	14	10	8	91
GN 40-50-M10-28-B0-X	50	M 10	28	6.6	2.5	-	38	-	14	10	8	79
GN 40-50-M10-28-A1-X	50	M 10	28	-	2.5	-	38	2	14	10	8	91
GN 40-50-M10-28-A3-X	50	M 10	28	-	2.5	4	38	-	14	10	8	87
GN 40-50-M12-32-A0-X	50	M 12	32	-	2.5	-	38	-	17	12	8	91
GN 40-50-M12-32-B0-X	50	M 12	32	6.6	2.5	-	38	-	17	12	8	95
GN 40-50-M12-32-A1-X	50	M 12	32	-	2.5	-	38	2	17	12	8	91
GN 40-50-M12-32-A3-X	50	M 12	32	-	2.5	4	38	-	17	12	8	103
GN 40-50-M16-37-A0-X	50	M 16	37	-	2.5	-	38	-	22	16	8	91
GN 40-50-M16-37-B0-X	50	M 16	37	6.6	2.5	-	38	-	22	16	8	111
GN 40-50-M16-37-A1-X	50	M 16	37	-	2.5	-	38	2	22	16	8	120
GN 40-50-M16-37-A3-X	50	M 16	37	-	2.5	4	38	-	22	16	8	120



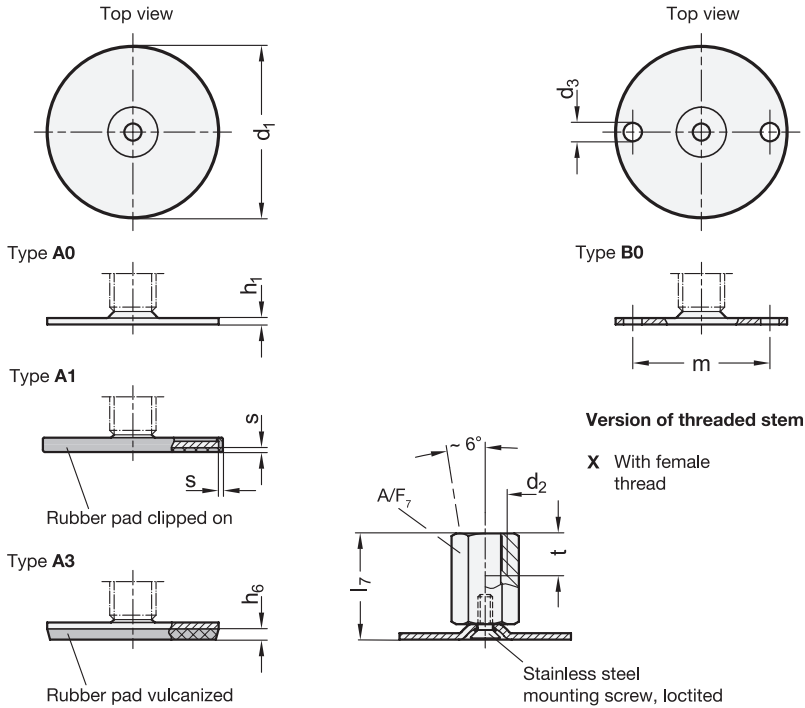

GN 40-X

Description	d1	d2	l7	d3	h1	h6	m	s	A/F 7	t	Static Load Fs in kN	⚖
GN 40-60-M8-25-A0-X	60	M 8	25	-	2.5	-	48	-	14	8	8	91
GN 40-60-M8-25-B0-X	60	M 8	25	6.6	2.5	-	48	-	14	8	8	98
GN 40-60-M8-25-A1-X	60	M 8	25	-	2.5	-	48	2	14	8	8	91
GN 40-60-M8-25-A3-X	60	M 8	25	-	2.5	4.5	48	-	14	8	8	91
GN 40-60-M10-28-A0-X	60	M 10	28	-	2.5	-	48	-	14	10	10	91
GN 40-60-M10-28-B0-X	60	M 10	28	6.6	2.5	-	48	-	14	10	10	96
GN 40-60-M10-28-A1-X	60	M 10	28	-	2.5	-	48	2	14	10	10	91
GN 40-60-M10-28-A3-X	60	M 10	28	-	2.5	4.5	48	-	14	10	10	110
GN 40-60-M12-32-A0-X	60	M 12	32	-	2.5	-	48	-	17	12	10	91
GN 40-60-M12-32-B0-X	60	M 12	32	6.6	2.5	-	48	-	17	12	10	111
GN 40-60-M12-32-A1-X	60	M 12	32	-	2.5	-	48	2	17	12	10	91
GN 40-60-M12-32-A3-X	60	M 12	32	-	2.5	4.5	48	-	17	12	10	126
GN 40-60-M16-37-A0-X	60	M 16	37	-	2.5	-	48	-	22	16	10	91
GN 40-60-M16-37-B0-X	60	M 16	37	6.6	2.5	-	48	-	22	16	10	128
GN 40-60-M16-37-A1-X	60	M 16	37	-	2.5	-	48	2	22	16	10	140
GN 40-60-M16-37-A3-X	60	M 16	37	-	2.5	4.5	48	-	22	16	10	143
GN 40-80-M8-26-A0-X	80	M 8	26	-	3	-	64	-	14	8	8	91
GN 40-80-M8-26-B0-X	80	M 8	26	6.6	3	-	64	-	14	8	8	158
GN 40-80-M8-26-A1-X	80	M 8	26	-	3	-	64	2	14	8	8	91
GN 40-80-M8-26-A3-X	80	M 8	26	-	3	5	64	-	14	8	8	169
GN 40-80-M10-29-A0-X	80	M 10	29	-	3	-	64	-	14	10	10	100
GN 40-80-M10-29-B0-X	80	M 10	29	8.6	3	-	64	-	14	10	10	156
GN 40-80-M10-29-A1-X	80	M 10	29	-	3	-	64	2	14	10	10	91
GN 40-80-M10-29-A3-X	80	M 10	29	-	3	5	64	-	14	10	10	187
GN 40-80-M12-32-A0-X	80	M 12	32	-	3	-	64	-	17	12	12	91
GN 40-80-M12-32-B0-X	80	M 12	32	8.6	3	-	64	-	17	12	12	172
GN 40-80-M12-32-A1-X	80	M 12	32	-	3	-	64	2	17	12	12	91
GN 40-80-M12-32-A3-X	80	M 12	32	-	3	5	64	-	17	12	12	203
GN 40-80-M16-38-A0-X	80	M 16	38	-	3	-	64	-	22	16	12	91
GN 40-80-M16-38-B0-X	80	M 16	38	8.6	3	-	64	-	22	16	12	189
GN 40-80-M16-38-A1-X	80	M 16	38	-	3	-	64	2	22	16	12	200
GN 40-80-M16-38-A3-X	80	M 16	38	-	3	5	64	-	22	16	12	221
GN 40-80-M20-45-A0-X	80	M 20	45	-	3	-	64	-	27	20	16	91
GN 40-80-M20-45-B0-X	80	M 20	45	8.6	3	-	64	-	27	20	16	251
GN 40-80-M20-45-A1-X	80	M 20	45	-	3	-	64	2	27	20	16	91
GN 40-80-M20-45-A3-X	80	M 20	45	-	3	5	64	-	27	20	16	284